

ENGINE

TRE 352

**IT Motore - MANUALE DI ISTRUZIONI**

ATTENZIONE: prima di usare la macchina, leggere attentamente il presente libretto.

**BG Мотора - УПЪТВАНЕ ЗА УПОТРЕБА**

ВНИМАНИЕ: преди да използвате машината прочетете внимателно настоящата книжка.

**BS Motora - UPUTSTVO ZA UPOTREBU**

PAŽNJA: prije nego što koristite ovu mašinu, pažljivo pročitajte priručnik s uputama.

**CS Motoru - NÁVOD K POUŽITÍ**

UPOZORNĚNÍ: před použitím stroje si pozorně přečtěte tento návod k použití.

**DA Motor - BRUGSANVISNING**

ADVARSEL: læs instruktionsbogen omhyggeligt igennem, før du tager denne maskine i brug.

**DE Motor - GEBRAUCHSANWEISUNG**

ACHTUNG: vor Inbetriebnahme des Geräts die Gebrauchsanleitung aufmerksam lesen.

**EL κινητήρα - ΟΔΗΓΙΕΣ ΧΡΗΣΗΣ**

ΠΡΟΣΟΧΗ: πριν χρησιμοποιήσετε το μηχάνημα, διαβάστε προσεκτικά το παρόν εγχειρίδιο.

**EN Engine - OPERATOR'S MANUAL**

WARNING: read thoroughly the instruction booklet before using the machine.

**ES Motor - MANUAL DE INSTRUCCIONES**

ATENCIÓN: antes de utilizar la máquina, leer atentamente el presente manual.

**ET Mootori - KASUTUSJUHEND**

TÄHELEPANU: enne masina kasutamist lugege tähelepanelikult antud kasutusjuhendit.

**FI Moottoriin - KÄYTTÖOHJEET**

VAROITUS: lue käyttöohje huolellisesti ennen koneen käyttöä.

**FR Moteur - MANUEL D'UTILISATION**

ATTENTION: lire attentivement le manuel avant d'utiliser cette machine.

**HR Motora - PRIRUČNIK ZA UPORABO**

POZOR: prije uporabe stroja, pažljivo pročitajte ovaj priručnik.

**HU Motor - HASZNÁLATI UTASÍTÁS**

FIGYELEM! a gép használatá előtt olvassa el figyelmesen a jelen kézikönyvet.

**LT Variklio - NAUDOJIMO INSTRUKCIJOS**

DĖMESIO: prieš naudojant įrenginį, atidžiai perskaityti šį naudotojo vadovą.

**LV Dzinēja - LIETOŠANAS INSTRUKCIJA**

UZMANĪBU: pirms aparāta lietošanai rūpīgi izlasiet doto instrukciju.

**MK Моторот - УПАТСТВА ЗА УПОТРЕБА**

ВНИМАНИЕ: прочитайте го внимателно ова упатство пред да ја користите машината.

**NL Motor - GEBRUIKERSHANDLEIDING**

LET OP: vooraleer de machine te gebruiken, dient men deze handleiding aandachtig te lezen.

**NO Motoren - INSTRUKSJONSBOK**

ADVARSEL: les denne bruksanvisningen nøye før du bruker maskinen.

**PL Silnika - INSTRUKCJE OBSŁUGI**

OSTRZEŻENIE: przed użyciem maszyny, należy uważnie przeczytać niniejszą instrukcję.

**PT Motor - MANUAL DE INSTRUÇÕES**

ATENÇÃO: antes de usar a máquina, leia atentamente o presente manual.

**RO Motor - MANUAL DE INSTRUCȚIUNI**

ATENȚIE: înainte de a utiliza mașina, citiți cu atenție manualul de față.

**RU двигателя - РУКОВОДСТВО ПО ЭКСПЛУАТАЦИИ**

ВНИМАНИЕ: прежде чем пользоваться оборудованием, внимательно прочтите это руководство по эксплуатации.

**SK Motora - NÁVOD NA POUŽITIE**

UPOZORNENIE: pred použitím stroja si pozorne prečítajte tento návod.

**SL Motorja - PRIROČNIK ZA UPORABO**

POZOR: preden uporabite stroj, pazljivo preberite priročnik z navodili.

**SR Motora - PRIRUČNIK SA UPUTSTVIMA**

PAŽNJA: pre korišćenja mašine pažljivo pročitati ovaj priručnik.

**SV Motor - BRUKSANVISNING**

VARNING: läs igenom hela detta häfte innan du använder maskinen.

**TR Motor - KULLANIM KILAVUZU**

DİKKAT: makineyi kullanmadan önce talimatlar içeren kilavuzu dikkatle okuyun.



|  |           |
|--|-----------|
| ITALIANO - Istruzioni Originali .....                                  | <b>IT</b> |
| БЪЛГАРСКИ - Инструкция за експлоатация .....                           | <b>BG</b> |
| BOSANSKI - Prijevod originalnih uputa .....                            | <b>BS</b> |
| ČESKY - Překlad původního návodu k používání .....                     | <b>CS</b> |
| DANSK - Oversættelse af den originale brugsanvisning .....             | <b>DA</b> |
| DEUTSCH - Übersetzung der Originalbetriebsanleitung .....              | <b>DE</b> |
| ΕΛΛΗΝΙΚΑ - Μετάφραση των πρωτοτυπων οδηγιων .....                      | <b>EL</b> |
| ENGLISH - Translation of the original instruction .....                | <b>EN</b> |
| ESPAÑOL - Traducción del Manual Original .....                         | <b>ES</b> |
| EESTI - Algupärase kasutusjuhendi tõlge .....                          | <b>ET</b> |
| SUOMI - Alkuperäisten ohjeiden käännös .....                           | <b>FI</b> |
| FRANÇAIS - Traduction de la notice originale .....                     | <b>FR</b> |
| HRVATSKI - Prijevod originalnih uputa .....                            | <b>HR</b> |
| MAGYAR - Eredeti használati utasítás fordítása .....                   | <b>HU</b> |
| LIETUVIŠKAI - Originalių instrukcijų vertimas .....                    | <b>LT</b> |
| LATVIEŠU - Instrukciju tulkojums no oriģināl valodas .....             | <b>LV</b> |
| МАКЕДОНСКИ - Превод на оригиналните упатства .....                     | <b>MK</b> |
| NEDERLANDS - Vertaling van de oorspronkelijke gebruiksaanwijzing ..... | <b>NL</b> |
| NORSK - Oversettelse av den originale bruksanvisningen .....           | <b>NO</b> |
| POLSKI - Tłumaczenie instrukcji oryginalnej .....                      | <b>PL</b> |
| PORTUGUÊS - Tradução do manual original .....                          | <b>PT</b> |
| ROMÂN - Traducerea manualului fabricantului .....                      | <b>RO</b> |
| РУССКИЙ - Перевод оригинальных инструкций .....                        | <b>RU</b> |
| SLOVENSKY - Preklad pôvodného návodu na použitie .....                 | <b>SK</b> |
| SLOVENŠČINA - Prevod izvirnih navodil .....                            | <b>SL</b> |
| SRPSKI - Prevod originalnih uputstva .....                             | <b>SR</b> |
| SVENSKA - Översättning av bruksanvisning i original .....              | <b>SV</b> |
| TÜRKÇE - Orijinal Talimatların Tercümesi .....                         | <b>TR</b> |

1

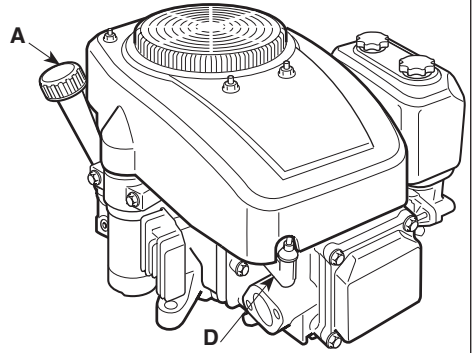
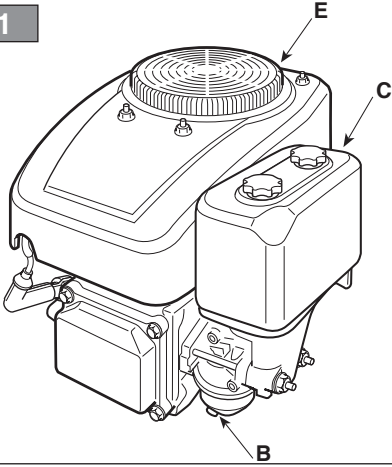

2

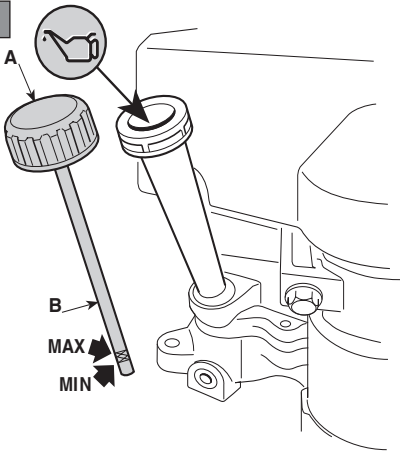

3

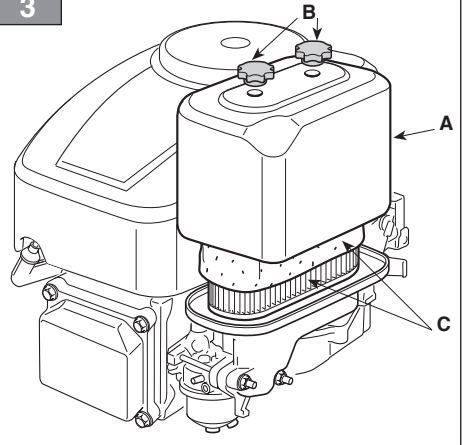

4

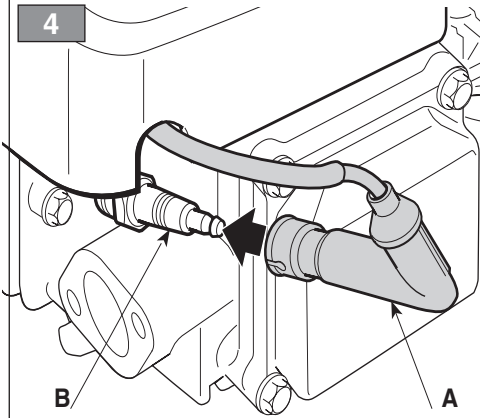

5

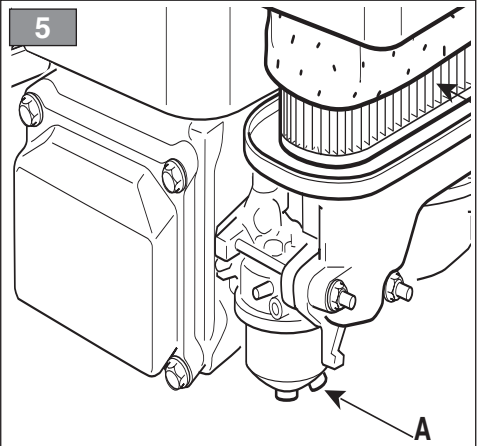

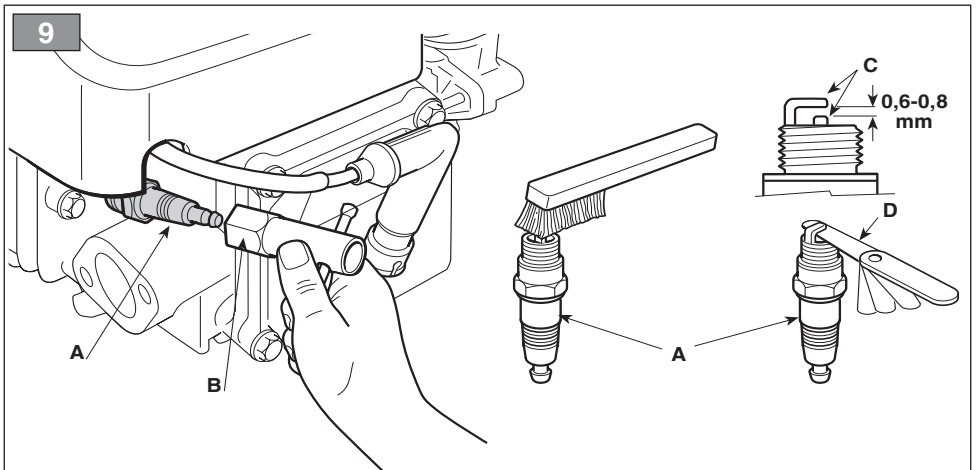
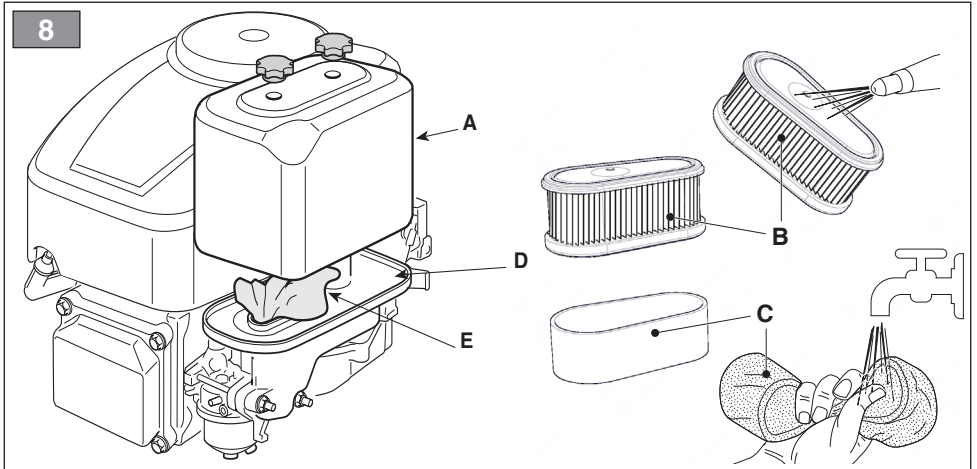
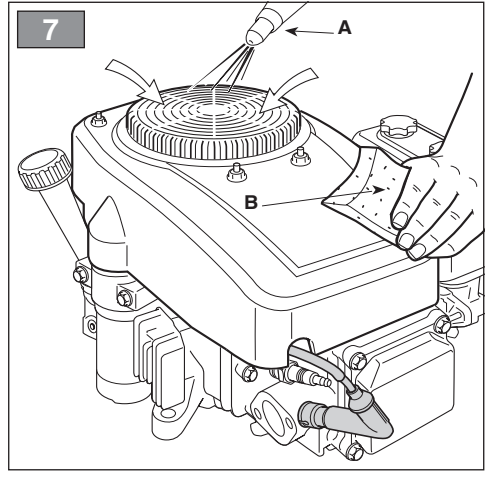
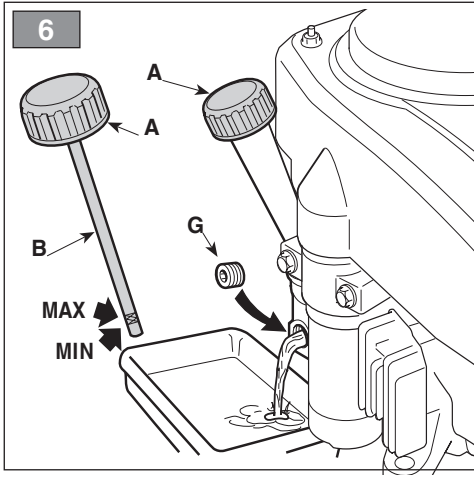

|   |  |   |
|---|--|---|
| <p>[1] <b>EN - TECHNICAL DATA</b><br/> [2] Fuel<br/> [3] Engine oil<br/> [4] Oil capacity<br/> [5] Spark plug<br/> [6] Electrode gap<br/> [7a] CO<sub>2</sub><br/> [7b] This CO<sub>2</sub> measurement results from testing over a fixed test cycle under laboratory conditions a(n) (parent) engine representative of the engine type (engine family) and shall not imply or express any guarantee of the performance of a particular engine.</p>   | <p>[1] <b>ES - DATOS TÉCNICOS</b><br/> [2] Combustible<br/> [3] Aceite del motor<br/> [4] Contenido del cárter<br/> [5] Bujía<br/> [6] Distancia entre los electrodos<br/> [7a] CO<sub>2</sub><br/> [7b] La presente medición de CO<sub>2</sub> es el resultado de ensayos realizados durante un ciclo de ensayo fijo en condiciones de laboratorio con un motor (de referencia) representativo del tipo de motor (familia de motores) de que se trate y no constituye garantía alguna ni implícita ni expresa del rendimiento de un motor concreto.</p> | <p>[1] <b>ET - TEHNILISED ANDMED</b><br/> [2] Kütus<br/> [3] Mootoriõli<br/> [4] Kogus<br/> [5] Küünal<br/> [6] Vahe elektroodide vahel<br/> [7a] CO<sub>2</sub><br/> [7b] Käesolevad CO<sub>2</sub> mõõtetulemused on saadud laboratoorses tingimustes püsikatsetsükli sõidukiitüüpi (mootoritüüpkonda) esindava representatiiv(alg) mootori peal ning ei anna ega väljenda mingit garantiid konkreetse mootori talitluse kohta</p>                  |
| <p>[1] <b>FI - TEKNISET TIEDOT</b><br/> [2] Polttoaine<br/> [3] Mootoriöljy<br/> [4] Öljysäiliön tilavuus<br/> [5] Sytytystulppa<br/> [6] Elektrodienväli<br/> [7a] CO<sub>2</sub><br/> [7b] Tämä CO<sub>2</sub>-mittaustulos on saatu moottorityypin (moottoriperhettä) edustavalle (kanta)moottorille laboratorio-olosuhteissa tehdystä kiinteässä testisyklissä, eikä se ole tae yksittäisen moottorin suorituskyvystä.</p>  | <p>[1] <b>FR - CARACTÉRISTIQUES TECHNIQUES</b><br/> [2] Carburant<br/> [3] Huile moteur<br/> [4] Contenu du bac à huile<br/> [5] Bougie<br/> [6] Distance entre les électrodes<br/> [7a] CO<sub>2</sub><br/> [7b] Cette mesure du CO<sub>2</sub> est le résultat d'un essai, réalisé sur un cycle fixe dans des conditions de laboratoire, portant sur un moteur [parent] représentatif du type de moteurs [de la famille de moteurs], et ne constitue pas une indication ou une garantie des performances d'un moteur particulier.</p>                  | <p>[1] <b>HR - TEHNIČKI PODACI</b><br/> [2] Gorivo<br/> [3] Motorno ulje<br/> [4] Sadržaj posude<br/> [5] Svjećica<br/> [6] Udaljenost između elektroda<br/> [7a] CO<sub>2</sub><br/> [7b] Ova izmjerenja vrijednost CO<sub>2</sub> rezultat je ispitivanja tijekom određenog ispitnog ciklusa u laboratorijskim uvjetima te ne podrazumijeva nikakvo implicitno ili izričito jamstvo o sposobnosti određenog motora.</p>                             |
| <p>[1] <b>HU - MŰSZAKI ADATOK</b><br/> [2] Üzemanyag<br/> [3] Motorolaj<br/> [4] Olajteknő kapacitás<br/> [5] Gyertya<br/> [6] Elektroódok közötti távolság<br/> [7a] CO<sub>2</sub><br/> [7b] Ez a CO<sub>2</sub>-érték a motor-típust (motorcsaládot) képviselő (alap)motoron, rögzített vizsgálati ciklus alatt, laboratóriumi körülmények között elvégzett vizsgálatból származik, és sem kifejezetten, sem hallgatólagosan nem jelent garanciát az adott motor teljesítményére vonatkozóan</p> | <p>[1] <b>LT - TECHINIAI DUOMENYS</b><br/> [2] Degalai<br/> [3] Variklio alyvos<br/> [4] Duginės talpa<br/> [5] Žvakės<br/> [6] Atstumas nuo elektrodo<br/> [7a] CO<sub>2</sub><br/> [7b] Šis CO<sub>2</sub> matavimo rezultatai gauti atliekant nustatytą bandymų ciklą laboratorinėmis sąlygomis su (pirminiu) varikliu, atitinkančiu variklio tipą (variklio šeima), ir jie neužtikrina ir negarantuoja konkretaus variklio eksploatacinių charakteristikų.</p>   | <p>[1] <b>LV - TEHNISKIE DATI</b><br/> [2] Degviela<br/> [3] Motoreļļa<br/> [4] Kausa saturs<br/> [5] Svece<br/> [6] Attālums starp elektrodiem<br/> [7a] CO<sub>2</sub><br/> [7b] Šis CO<sub>2</sub> mērījumu rezultāts iegūts, testējot motora tipu (motoru saimi) pārstāvošo (cilmes) motoru fiksētā testa ciklā laboratorijas apstākļos, un nedrīkst netieši norādīt vai izteikt jebkādu garantijas izpildījumu attiecībā uz konkrēto motoru.</p> |



## INDEX

|   |   |
|---|---|
| 1. GENERAL INFORMATION.....                             | 1 |
| 2. SAFETY REGULATIONS.....                              | 1 |
| 3. ABOUT THE MACHINE.....                               | 3 |
| 3.1 Machine description and intended use..              | 3 |
| 3.2 Safety signs .....                                  | 3 |
| 3.3 Identification label .....                          | 3 |
| 3.4 Engine components .....                             | 3 |
| 3.5 Environmental conditions .....                      | 4 |
| 3.6 Fuel .....  | 4 |
| 3.7 Oil .....   | 4 |
| 3.8 Air filter.....                                     | 4 |
| 3.9 Spark plug.....                                     | 4 |
| 4. CONTROLS.....  | 4 |
| 4.1 Accelerator control.....                            | 4 |
| 5. REGULATIONS FOR USE.....                             | 5 |
| 5.1 Before each use .....                               | 5 |
| 5.2 Starting the engine (cold start) .....              | 5 |
| 5.3 Starting the engine (warm start) .....              | 5 |
| 5.4 Engine use during operation .....                   | 5 |
| 5.5 Stopping the engine during operation ...            | 5 |
| 5.6 Stopping the engine at the end of<br>operation..... | 6 |
| 5.7 Cleaning and storage .....                          | 6 |
| 5.8 Prolonged downtime .....                            | 6 |
| 6. MAINTENANCE .....                                    | 6 |
| 6.1 General .....                                       | 6 |
| 6.2 Maintenance table.....                              | 6 |
| 6.3 Oil change.....                                     | 7 |
| 6.4 Cleaning the silencer and the engine ....           | 7 |
| 6.5 Air filter maintenance .....                        | 7 |
| 6.6 Spark plug checks and maintenance ....              | 7 |
| 7. TROUBLESHOOTING.....                                 | 8 |

## 1. GENERAL INFORMATION

### 1.1 HOW TO READ THIS MANUAL

Some of the paragraphs in this manual contain particularly important information in terms of safety and operation, and are highlighted differently, according to the following criteria:

**NOTE** or **IMPORTANT** *this paragraph provides details or further information on what has already been said, with the aim of preventing damage to the machine or other damage.*

The  symbol represents a danger. Failure to observe the warning can lead to possible personal and/or third party injury and/or damage.

### 1.2 REFERENCES

#### 1.2.1 Figures

The figures in these instructions for use are numbered 1, 2, 3, and so forth. The components identified in the figures are marked with letters A, B C and so forth. A reference to component C in figure 2 is represented by: "See fig. 2.C" or simply "(Fig. 2.C)".

The figures are provided by way of example. The effective prices can vary in comparison to the ones provided here.

#### 1.2.2 Titles

The manual is arranged in chapters and paragraphs. The title of paragraph "2.1 Training" is a sub-title of "2. Safety regulations". The references to titles or paragraphs are marked with the abbreviation chap. or par. and the relative number. Example: "chap. 2" or "par. 2.1".

## 2. SAFETY REGULATIONS

### 2.1 TRAINING

 **Read these instructions carefully before using the machine.**

 **Familiarise with the controls and with appropriate use of the machine. Learn how to stop the engine quickly. Failure to observe warnings and instructions can cause fires and/or serious injury. Keep all warnings and instructions safe for future reference.**

- Never allow the machine to be used by children or individuals who are not familiar with the instructions. Local laws may establish a minimum age for users.
- Never use the machine if the user is tired or unwell, or has taken medication, drugs, alcohol or substances that impair reflexes and concentration.
- Remember that the operator or user is responsible for accidents and unexpected events that can occur to other people or property.

## 2.2 PRELIMINARY OPERATIONS

### Personal Protective Equipment (PPE)

- Never use the machine without wearing suitable clothing.
- Never wear loose clothing, laces, jewellery or other objects that can get caught; tie back long hair and maintain the safety distance at start-up.
- Wear noise cancelling headphones.

### Work / Machine Area

- Before starting the engine ensure that all of the controls operating the moving parts of the machine are disconnected.

### Internal combustion engine: fuel

- Warning: the fuel is highly flammable. Handle with care!
  - Always store the fuel in suitable containers.
  - Fill up or top up using a funnel, only outdoors and never smoke during these operations.
  - Fill up before turning the engine on. Never open the tank cap or fill up when the engine is running or still warm.
  - If any fuel spills out do not start the engine, rather, move the machine away from the spillage and immediately clean up every trace of fuel that has spilled on to the machine or ground.
  - Firmly screw the fuel container tank cap back on.
  - Avoid getting any fuel or your clothing and, if this should happen, change your clothes before starting the engine.

## 2.3 DURING USE

### Work Area

- Do not use the machine in environments that pose the risk of explosion, in the presence of flammable liquids, gases or powders. Electrical contact or mechanical rubbing can generate sparks that can ignite powder or vapour.
- Do not operate the engine in confined spaces where dangerous carbon monoxide fumes can collect. The start-up operations must be carried out outdoors or in a well-ventilated area. Always remember that the exhaust gases are toxic.
- Keep people, children and animals away from the work area. Children must be supervised by another adult.

### Conduct

- Before making repairs, cleaning, performing inspections, adjustments, turn the engine off and disconnect the spark plug cable (unless explained otherwise in the instructions).
- Do not touch the parts of the engine that heat up during operation. Risk of burns.

### Restrictions of use

- Do not use the machine if there are not enough protections or if the safety devices are not set up correctly.
- Do not disconnect or tamper with the installed safety systems.
- Do not change the engine adjustments, or exceed the maximum rpm. If the engine is forced to run at an excessive speed, the risk of personal injury increases.
- Do not use starter fluids or other similar products.
- Do not tilt the machine onto its side to the point where fuel leaks from the fuel tank cap.
- Do not crank the engine without spark plug.

## 2.4 MAINTENANCE, STORAGE AND TRANSPORT

Servicing the machine on a regular basis and correct storage maintain machine safety.

 **Broken or worn parts must be replaced and never repaired. Only use original parts: using parts that are not original or installed incorrectly affects machine safety, and can therefore cause accidents or personal injury and relieve the Manufacturer of all obligations and liability.**

### Maintenance

- If the tank can be emptied, perform this operation outdoors and when the motor is cold.

- To reduce the risk of fire, check for oil and/or fuel leaks on a regular basis.

### Storage

- Never leave fuel in the tank if the machine is stored in a building where the fuel vapours can come into contact with open flames, sparks or sources of heat.
- Let the machine cool down before storing it indoors.

### Transport

- Transport the machine with an empty tank.

## 2.5 ENVIRONMENTAL PROTECTION

Protecting the environment must be a significant and top priority for machine use, to the benefit of civil co-habitation and of the environment that we live in.

- Avoid being an element of disturbance to the surrounding area.
- Follow local regulations closely for the disposal of packaging, oils, fuels, filters, worn parts or any element that strongly impacts the environment; this waste must not be disposed of with regular waste, but must be separated and taken to collection centres, who will recycle the materials.
- At the time of decommissioning, do not leave the machine in the environment, rather, contact a collection centre, in accordance with local regulations in force.

## 2.6 EMISSIONS

The combustion process generates toxic substances such as carbon monoxide, nitrogen oxides and hydrocarbons. It is important to control these substances because they can react with photochemical smog as well as with direct exposure to sunlight. Carbon monoxide does not react in the same way to exposure to sunlight but it must still be considered toxic.

Our machines are equipped with emission reduction systems for the substances mentioned above.

## 3. ABOUT THE MACHINE

### 3.1 MACHINE DESCRIPTION AND INTENDED USE

#### This machine is a spark-ignition engine

Engine performance, reliability and life are influenced by many factors, some external and some strictly associated with the quality of the employed products and with the scheduled maintenance. Additional information is provided below for greater awareness of your machine. Any other use that does not comply with the above, can be dangerous and cause damage to people and/or property.

**IMPORTANT** *Improper use of the machine causes the warranty to lapse and relieves the Manufacturer of any liability, placing all responsibility for damage or injury, to him/herself or third parties, on the user.*

#### 3.1.1 Type of users

This machine is intended for use by consumers, i.e. non-professional operators. It is intended for "hobby-related activities"

### 3.2 SAFETY SIGNS

There are various symbols on the machine. Their function is to remind the operator of the correct conduct for use, with due care and caution.

Meanings of the symbols:



**ATTENTION!** The muffler may be very hot. Do not touch.



**ATTENTION!** Top up the oil until it reaches the «MAX» level. Do not exceed the «MAX» level.

### 3.3 IDENTIFICATION LABEL

Write the serial number (S7n) of your machine on the space provided on the label at the back of the cover.

### 3.4 ENGINE COMPONENTS

The machine is comprised of the following main parts (fig. 1).

- Oil filler cap with dipstick
- Carburettor
- Air filter cover
- Spark plug cap
- Engine code



### 3.5 ENVIRONMENTAL CONDITIONS

The operation of a four-stroke endothermic engine is affected by:

#### a) Temperature:

- When operating at low temperatures cold starts may be difficult.
- When operating at very high temperatures warm starts may be difficult due to evaporation of the fuel in the float chamber of the carburettor or in the pump.
- In any case the right kind of oil must be used, according to the operating temperatures.

#### b) Altitude:

- The higher the altitude above sea level, the lower the max power developed by an endothermic engine.
- When there is a considerable increase in altitude, the load on the machine should be reduced and particularly heavy work avoided.

### 3.6 FUEL

A good quality fuel is the major issue for the engine reliability of operation.

Fuel must meet these requirements:

- Use clean, fresh unleaded gasoline, with a minimum of 90 octane.
- Do not use fuel formulated with ethanol greater than 10%.
- Do not add oil.
- To protect the fuel system from gum formation, mix a fuel stabilizer into the fuel.

Use of unapproved fuels will cause damage to engine components, which will not be covered under warranty.

**NOTE** *Only use the fuel named in the technical data table. Do not use other types of fuel. It is possible to use ecological fuels, such as alkylate petrol. The composition of this petrol has less of an impact on people and animals. No negative effects have been reported in connection to their use. Nonetheless, there are types of alkylate petrol on the market for which it is not possible to provide specific indications on their use.*

### 3.7 OIL

Use always high quality oils, choosing their viscosity grade according to the operating temperature.

- Only use detergent oil with a quality of no less than SF-SG.
- Choose the SAE viscosity based on the technical data table.
- The use of multigrade oil can lead to greater consumption in hot weather, accordingly it is necessary to check the level more frequently.
- Do not mix oils of different brands and characteristics.
- SAE 30 oil, if used below +5°C, could result in possible engine damage due to inadequate lubrication.

### 3.8 AIR FILTER

The air filter must always be in perfect working order, to prevent debris and dust from getting sucked into the engine, reducing the efficiency and life of the machine.

- Always keep the filtering element free of debris and in perfect working order (par. 6.5).
- If necessary, replace the filtering element with an original spare part. Incompatible filtering elements can impair the efficiency and life of the engine.
- Never start the engine without mounting the filtering element properly.

### 3.9 SPARK PLUG

Not all the spark plugs for endothermic engines are the same.

- Use only spark plugs of the recommended type, with the right heat range.
- Check the length of the thread, because - if too long - it will damage the engine beyond repair.
- Make sure that the electrodes are clean and that their gap is correct (par. 6.6).

## 4. CONTROLS

### 4.1 ACCELERATOR CONTROL

This controls engine rpm.

The throttle trigger (generally a lever), fitted to the machine, is connected to the engine by a cable.

Consult the machine's Instructions Manual to identify the throttle trigger and its positions, usually marked by symbols, corresponding to:

- **FAST** = corresponds to maximum revs; to be used when working.
- **SLOW** = corresponds to minimum revs.
- **CHOKE** = to be used for cold starts (when applicable)

## 5. REGULATIONS FOR USE

### 5.1 BEFORE EACH USE

Before every use, perform the following checking procedures in order to assure a regular operation. The fuel characteristics are provided in the specific paragraph (see 4.2 and 8.1).

#### 5.1.1 Oil level check

1. Place the machine on a flat surface.
2. Clean around the oil fill cap.
3. Unscrew the cap (fig. 2.A), clean the end of the dipstick (fig. 2.B) and slide it back in until the cap is touching the hole, as shown, without screwing it back on.
4. Remove the cap with the dipstick and check the oil level that must be between the «MIN» and «MAX» marks.
5. If oil is required, add oil of the same kind up to the «MAX» mark, being careful not to spill any outside the oil fill.
6. Fully tighten the filler cap (fig. 2.A) and wipe off any spilled oil.

**NOTE** *Top up gradually, adding small amounts of oil, checking the level each time. Do not top up beyond the «MAX» level; an excessive level can cause:*

- smoking from the exhaust;
- soiling of the spark plug or air filter with subsequent difficulty for ignition.

**NOTE** *For the required type of oil, observe the indications provided in the technical data table.*

#### 5.1.2 Air filter control

The efficiency of the air filter is essential to correct engine operation; do not start up the engine if there is no filtering element or it is broken.

1. Clean around the filter cover (fig. 3.A).
2. Take the cover off (fig. 3.A) by unscrewing the two knobs (fig. 3.B).
3. Check the state of the filtering element (fig. 3.C), which must be intact, clean and in perfect working order; otherwise service or replace it (par. 6.5).
4. Put the cover back in place (fig. 3.A).

#### 5.1.3 Refuelling

The refuelling operations are described in the machine manual and are mentioned here.

To refuel:

1. Unscrew the fuel cap and take it off.
2. Set a funnel on the hole.
3. Refuel and take the funnel off.
4. At the end of refuelling, screw the cap back on and clean any spillage.

**IMPORTANT** *Avoid getting fuel on the plastic parts of the engine or machine to avoid damaging them, and immediately clean off every trace of spilled fuel. The warranty does not cover damage to plastic parts caused by fuel.*

#### 5.1.4 Spark plug cap

Firmly connect the cap (fig. 4.A) of the spark plug cable (fig. 4.B), ensuring that there are no traces of dirt inside the cap or on the spark plug terminal.

### 5.2 STARTING THE ENGINE (COLD START)

The engine must be started up as described in the machine's Instructions Manual, always being careful to uncouple any device (if applicable) that is capable of making the machine travel forwards or stop the engine.

1. Place the throttle on «CHOKE» (if applicable) or «FAST».
2. Turn the starter key as described in the machine's Instructions Manual.

After a few seconds, gradually move the throttle from «CHOKE» (if applicable) to «FAST» or «SLOW».

### 5.3 STARTING THE ENGINE (WARM START)

Follow the entire procedure described for cold starts, with the throttle on «FAST».

### 5.4 ENGINE USE DURING OPERATION

To optimise engine output and performance, it must be used at maximum rpm, by placing the throttle on «FAST».

**IMPORTANT** *Do not work on slopes exceeding 20° to avoid jeopardising correct engine operation.*

### 5.5 STOPPING THE ENGINE DURING OPERATION

1. Place the throttle on «SLOW».
2. Let the engine run at minimum for at least 15-20 seconds.

3. Stop the engine following the instructions contained in the machine's Instructions Manual.

### 5.6 STOPPING THE ENGINE AT THE END OF OPERATION

1. Place the throttle on «SLOW».
2. Let the engine run at minimum for at least 15-20 seconds.
3. Stop the engine following the instructions contained in the machine's Instructions Manual.
4. With a cold engine, take the cap off the spark plug (fig. 4.A) and take out the starter key (if applicable).
5. Remove any debris from the engine and especially around the exhaust silencer to reduce the risk of fire.

### 5.7 CLEANING AND STORAGE

- Do not spray with water or use pressure washer wands to clean the exterior of the engine.
- Preferably use a compressed air gun (max. 6 bars), thus preventing debris and dust from penetrating inside.
- Store the lawnmower (and the engine) in a dry place, sheltered from the elements and sufficiently ventilated.

### 5.8 PROLONGED DOWNTIME

If the engine is not going to be used for more than 30 days (for example, at the end of the season), it will be necessary to take a few precautions so that it will start back up again accordingly.

- Empty the fuel tank, to avoid deposits from forming inside, by unscrewing the cap (fig. 5.A) of the fuel tank and collecting all of the fuel in a suitable container. At the end of this operation, remember to screw the cap back on (fig. 5.A) tightly.
- Remove the spark plug and pour about 3 cl of clean engine oil into the spark plug hole, then, having blocked the hole with a rag, run the starter motor briefly to turn the engine for a few revs and distribute the oil over the inner surface of the cylinder. Finally, replace the spark plug without connecting the cable cap.

## 6. MAINTENANCE

 **Any attempt to tamper with the emission control system may increase emission levels above legal limits. This definition includes the removal or alteration of parts such as the intake system, the fuel system and the exhaust system.**

### 6.1 GENERAL

 **The safety regulations that must be followed during maintenance are described in par. 2.4.**

 **All controls and maintenance operations must be carried out with the machine off and the engine off. Disconnect the spark plug and read the relative instructions before starting any cleaning or maintenance procedure. Wear suitable clothing, gloves and glasses before performing any maintenance.**

- The frequency and type of procedures are outlined in the "Maintenance table".
- The use of non-original parts and accessories could have negative effects on machine operation and safety. The manufacturer declines any responsibility for damage or injury caused by said products.
- Original parts are supplied by assistance shops and authorised dealers.

**IMPORTANT** *All maintenance and adjustment operations that are not described in this manual must be carried out by your Dealer or by a Specialised Centre.*

### 6.2 MAINTENANCE TABLE

**IMPORTANT** *It is the responsibility of the owner to perform the machine maintenance operations described in the table below.*

**IMPORTANT** *Clean more frequently when operating in particularly demanding conditions or when there is debris in the air.*

**NOTE** *Filters should be cleaned / replaced more often if the machine is used on very dusty ground.*

| Operation  | After the first 5 hours | Every 5 hours or after every use | Every 50 hours or at the end of the season | Every 100 hours |
|--|-------------------------|----------------------------------|--|-----------------|
| Oil level check (par. 5.1.1)                               | -                       | √                                | -  | -               |
| Oil change <sup>1</sup> (par. 6.3)                         | √                       | -                                | √  | -               |
| Cleaning the silencer and the engine (par. 7)              | -                       | √                                | -  | -               |
| Checking and cleaning the air filter <sup>2</sup> (par. 8) | -                       | √                                | -  | -               |
| Changing the air filter (par. 8)                           | -                       | -                                | √  | -               |
| Spark plug check (par. 9)                                  | -                       | -                                | √  | -               |
| Changing spark plugs (par. 9)                              | -                       | -                                | -  | √               |
| Fuel filter check <sup>3</sup>                             | -                       | -                                | -  | √               |

<sup>1</sup> Change the oil every 25 hours if the engine is operating under heavy load or in hot weather.

<sup>2</sup> Clean the air filter more frequently if the machine is operating in dusty areas.

<sup>3</sup> To be carried out by a Specialised Centre.

### 6.3 OIL CHANGE

For the required type of oil, observe the indications provided in the technical data table.

**⚠ Drain the oil out while the engine is warm, being careful not to touch the hot engine nor the drained oil.**

Unless otherwise stated in this machine Instruction Manual, to change the oil it is necessary to:

1. Place the machine on a flat surface.
2. Clean around the filler cap and unscrew the cap with dipstick (fig. 6.A).
3. Provide a suitable container for collecting the oil and unscrew the drain plug (fig. 6.G).
4. Refit the drain plug (fig. 6.G) and tighten it.
5. Top up with new oil (par. 5.1.1).
6. Check that the oil level has reached the «MAX» notch on the dipstick (fig. 6.B).
7. Close the cap (fig. 6.A) again and clean up any traces of oil that was possibly spilt.

### 6.4 CLEANING THE SILENCER AND THE ENGINE

The silencer must be cleaned when the engine is cold.

- Use a jet of compressed air (fig. 7.A) to remove any debris and dirt that could cause a fire from the silencer and its protective cover.
- Ensure that the cooling air intakes are not obstructed (fig. 7.A).
- Clean the plastic parts with a sponge (fig. 7.B) soaked in water and detergent.

### 6.5 AIR FILTER MAINTENANCE

1. Clean around the filter cover (fig. 8.A).
2. Take the cover off (fig. 8.A) by unscrewing the two knobs.
3. Remove the filtering element (fig. 8.B + 8.C).
4. Take the pre-filter (fig. 8.C) out of the cartridge (fig. 8.B).
5. Tap the cartridge (fig. 8.B) on a solid surface and blow it from the inside with compressed air to remove dust and debris.
6. Wash the pre-filter sponge (fig. 8.C) with water and detergent and leave it to air dry.

**IMPORTANT** *Do not use water, petrol, detergents or any other products to clean the cartridge.*

**IMPORTANT** *The pre-filter sponge (fig. 8.C) must NOT be oiled.*

1. Clean out any dust and debris from inside the filter housing (fig. 8.D) being careful to close the extraction duct with a cloth (fig. 8.E) to stop them from getting into the engine.
2. Remove the cloth (fig. 8.E), place the filtering element (fig. 8.C + 8.B) in its housing and put the cover back in place (fig. 8.A).

### 6.6 SPARK PLUG CHECKS AND MAINTENANCE

1. Take the spark plug down (fig. 9.A) using a socket wrench (fig. 9.B).
2. Clean the electrodes (fig. 9.C) with a metal brush, removing any carbonaceous build-up.
3. Using a thickness gauge (fig. 9.D) ensure the gap between electrodes is correct (0.6 - 0.8 mm).
4. Put the spark plug back in (fig. 9.A) and tighten firmly using a socket wrench (fig. 9.B).

Replace the spark plug if the electrodes are burnt or if the porcelain is broken or damaged.

 **Fire hazard! Do not check the ignition system when the spark plug is not in place.**

**IMPORTANT** Only use the required type of spark plugs (see Technical data table).

## 7. TROUBLESHOOTING

| PROBLEM                           | PROBABLE CAUSE  | SOLUTION   |
|-----------------------------------|---|--|
| 1. Difficulty starting the engine | No fuel   | Check and top up (chap. 5.1.3)                                 |
|                                   | Old fuel or deposits in the fuel tank   | Empty the fuel tank and add fresh fuel                         |
|                                   | Incorrect starting procedure  | Perform start-up correctly (par. 5.2 and par. 5.3)             |
|                                   | Disconnected spark plug   | Ensure that the cap is fitted onto the spark plug (par. 5.1.4) |
|                                   | The spark plug is wet or the spark plug electrodes are dirty or placed inadequately | Check (par. 6.6)   |
|                                   | Clogged air filter  | Check and clean (par. 6.5)                                     |
|                                   | Incorrect oil for the season  | Replace with suitable oil (par. 6.3)                           |
|                                   | Fuel evaporation in the carburettor (vapor lock) due to elevated temperatures       | Wait a few minutes then try starting it up again (par. 5.3)    |
|                                   | Carburation fault   | Contact an Authorised Assistance Centre                        |
| 2. Irregular operation            | Ignition problems   | Contact an Authorised Assistance Centre                        |
|                                   | Dirty spark plug electrodes or incorrect gap  | Check (par. 6.6)   |
|                                   | The spark plug cap inserted incorrectly   | Ensure that the cap is firmly fitted on (par. 5.1.4)           |
|                                   | Clogged air filter  | Check and clean (par. 6.5)                                     |
|                                   | Throttle on «CHOKE» (if applicable)   | Move it to «FAST»  |
|                                   | Carburation fault   | Contact an Authorised Assistance Centre                        |
| 3. Loss of power during operation | Ignition problems   | Contact an Authorised Assistance Centre                        |
|                                   | Clogged air filter  | Check and clean (par. 6.5)                                     |
|                                   | Carburation fault   | Contact an Authorised Assistance Centre                        |

If problems persist after implementing the solution, contact your Dealer.